

PRO-MIC Update

Digital PRO-MIC
U-400

PRO-MIC Puts an End to Calibration!

All New PRO-MIC Digital 6000 Series

PRO-MIC Digital Features:

- **No calibration** required!
- **All new** Digital system.
- **Magnescale Probes** - Specially developed probes generate High Precision using a ferromagnetic rod and **magnetic flux measuring head** - details on reverse.
- **Increased Range: 0.400"** or 10mm.
- **Increased Resolution: 0.000020"** or 0.0005mm.
- **Exchange or replace** probes without accuracy loss.

New PRO-MIC Enhancements:

- **Super Bright** LED Backlight LCD Display
- **Super Battery** - 80% longer life.
- **Self Starting** - no more jump-starting.
- Ready for **Feed Line Detection** with PRO-MICs Optical Surface Sensors.
- Ready for **Temperature Profiles** with infrared Temperature Sensors.
- **Compatible** with current Saddles, Chargers, Printers, PDLs, PRO-FILERS and PRO-MIC Computer Systems.
- Direct **RS-232** Communication with PC.
- One, two or four probe configurations.

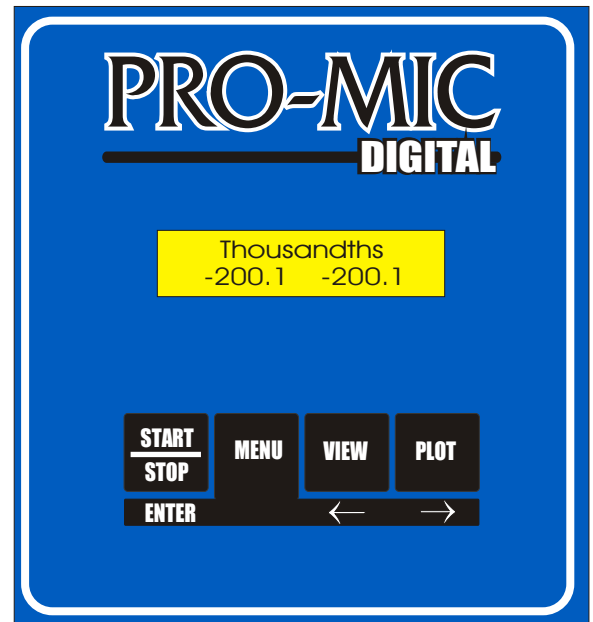

PRO-MIC Corporation
20135 Valley Forge Circle
King of Prussia, PA 19406
Phone: 610/783-7901 Fax: 610/783-7904
1-800-PRO-MIC-1
www.pro-mic.com

All New PRO-MIC Digital 6000 Series

PRO-MIC 6000 Digital Probe Details Magnescale Probes High Precision and Reliability

The sliding part of the measurement spindle is oil-sealed using Y-gaskets and O-rings to ensure dust-proof, splash-proof, and oil-resistant integrity. This enables highly efficient measurement even in our real world presence of flying dust and oil and coolant.

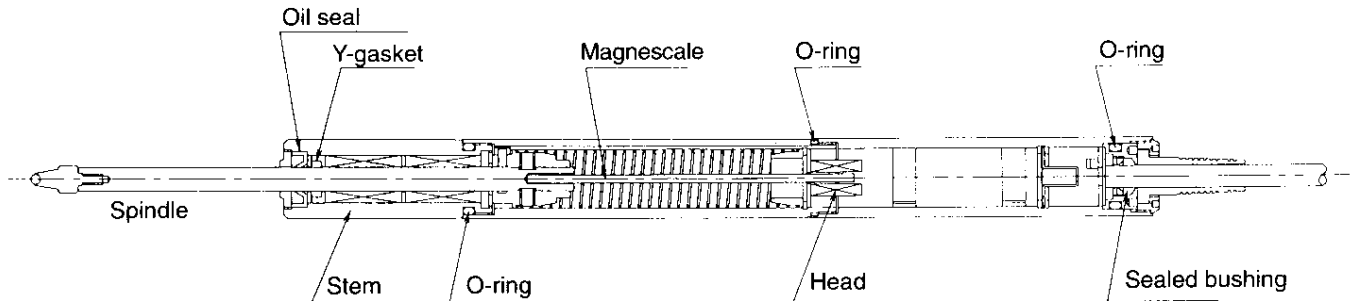

The Magnescale is a 2mm diameter rod made of ferromagnetic alloy recorded with 0.2mm pitch **magnetic graduations** (magnetization patterns). During manufacturing, the use of a special recording head and a **laser measuring** machine makes these graduations extremely accurate.

The measuring unit uses a magnetic flux responsive **multi-gap head** developed by Sony* to detect the magnetization pattern on the Magnescale as a signal corresponding to the amount of movement.

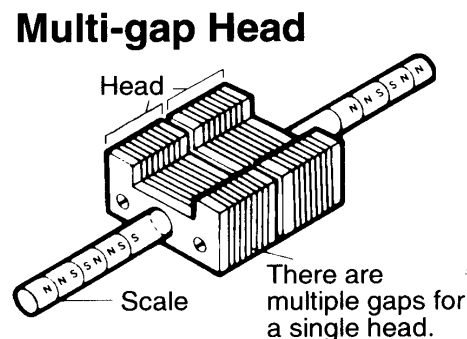
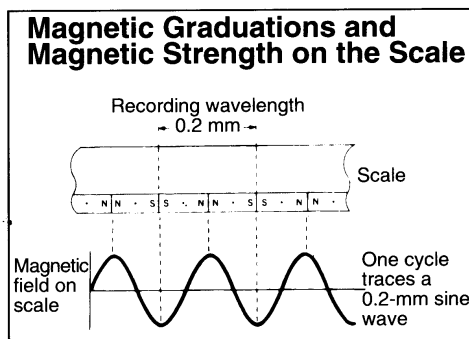

Then electrical techniques are used to separate the signals detected by the head and to output them as high-resolution digital signals.

These techniques have been in use in high-precision manufacturing environment for years. Now PRO-MIC puts Digital technology to use in your roll shop, measuring your rolls with never before seen reliability, accuracy and trouble free operation without the bother of periodic calibration.

*Adapted from Sony Magnescale Operating Principles